

Specifications

NKLA57

- * Stroke Length: 50~1500mm
- * Color: Silver Grey
- * IP Grade: IP65
- * Operating Temperature: -20°C~+60°C
- * Standard: CE
- * For solar tracking



Load and Speed

Dynamic Load(N)	12000
Static Load(N)	60000 (stroke≤1000mm)
Input(VDC)	12/24VDC or 120/230VAC
Speed(mm/s)	2.5

Dimensions

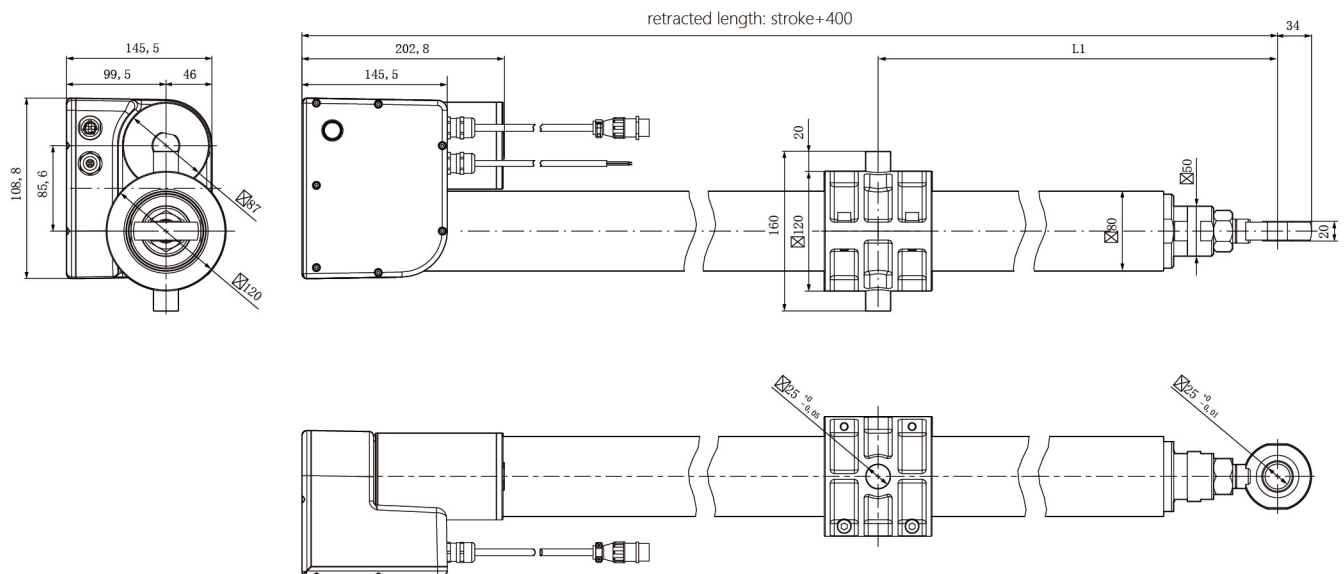

Additional Chart

Installation design of trunnion:

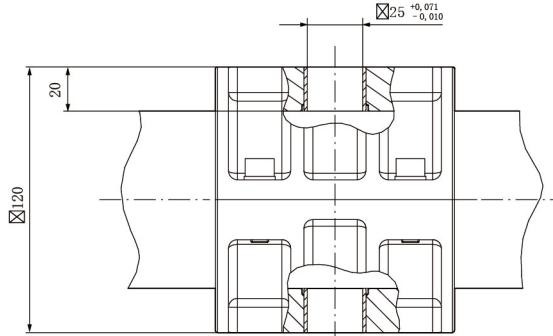

Trunnion 25mm casing pipe

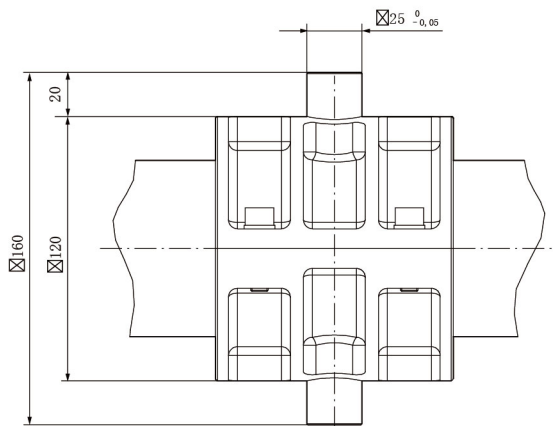

Trunnion 25mm pin

Connection diagram:

